

MOUNTING KIT



CopBox models which do not allow for spare tire access will not be shipped with the gas shocks or side gas shock bracket.

WE BUILD IT BETTER



CopBox ONLY FROM CTECH
CABINETS TACTICAL[®]
STORAGE

FORD INTERCEPTOR UTILITY
COPBOX
INSTALLATION GUIDE

SPARE TIRE ACCESS

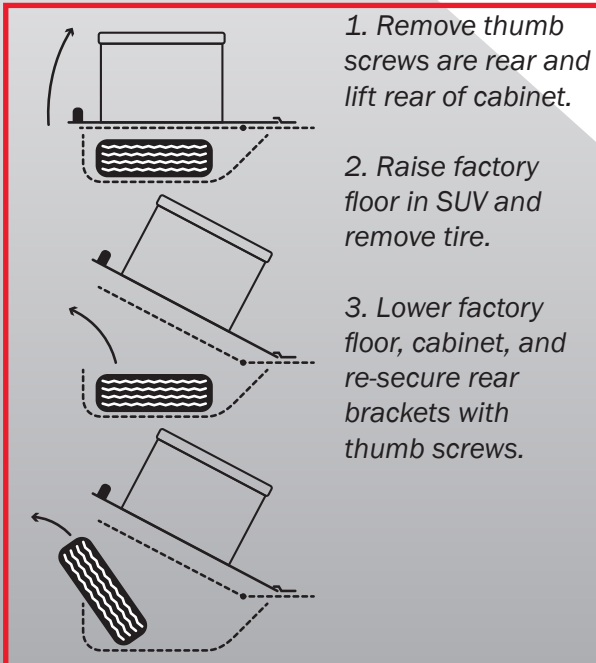

1. Remove thumb screws are rear and lift rear of cabinet.

2. Raise factory floor in SUV and remove tire.

3. Lower factory floor, cabinet, and re-secure rear brackets with thumb screws.

7501 Commerce Dr
Weston, WI 54476

715.355.8842



TACTICAL

INTERCEPTOR INSTALLATION STEPS:

1. Install front Z-Rail mount with 8mmx100 bolts with lock washer and space between vehicle floor and z-rail.

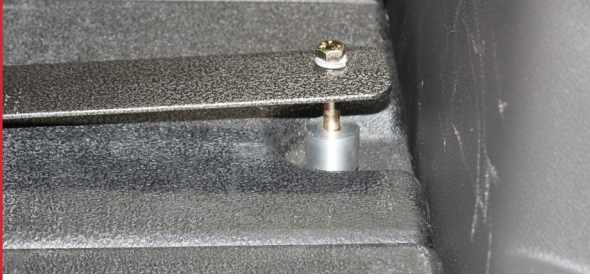

2. Remove factory cargo sill trim. Install rear mount brackets with 6mm bolts and lock washer.



3. Reinstall factory cargo sill trim.



4. *Spare tire access models only*
Remove factory hook from side panels, install right and left gas shock bracket using factory hook.



5. (2 person job) Slide CopBox into rear of SUV and slide front lip into the front z-rail mount. Secure the rear with CTECH thumb screws.



6. *Spare tire access models only*
Snap gas shock assist to the ball knobs on side brackets and CopBox.

